

TTXE SERIES

Technical Reference Guide

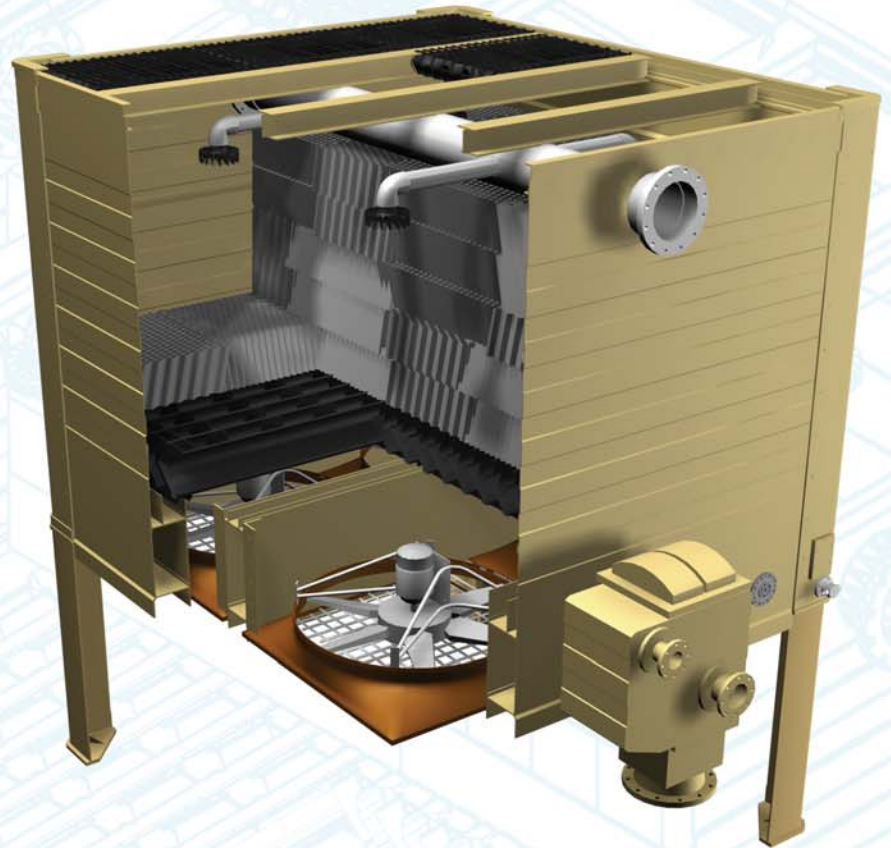

 **TOWER TECH**
COOLING TOWERS FOR DISCERNING USERS™

THROUGH
PERIMETER
FLOW-THRU BASIN™

SUMP DISCHARGE

TTXE SERIES

FEATURES:

The TTXE Series forced-draft, counter-flow cooling tower delivers reliable thermal performance in both constant and variable heat load applications. Its modular design enables easy interconnectability to create virtually any size cooling tower and quickly accommodates future expansion of cooling tower capacity.

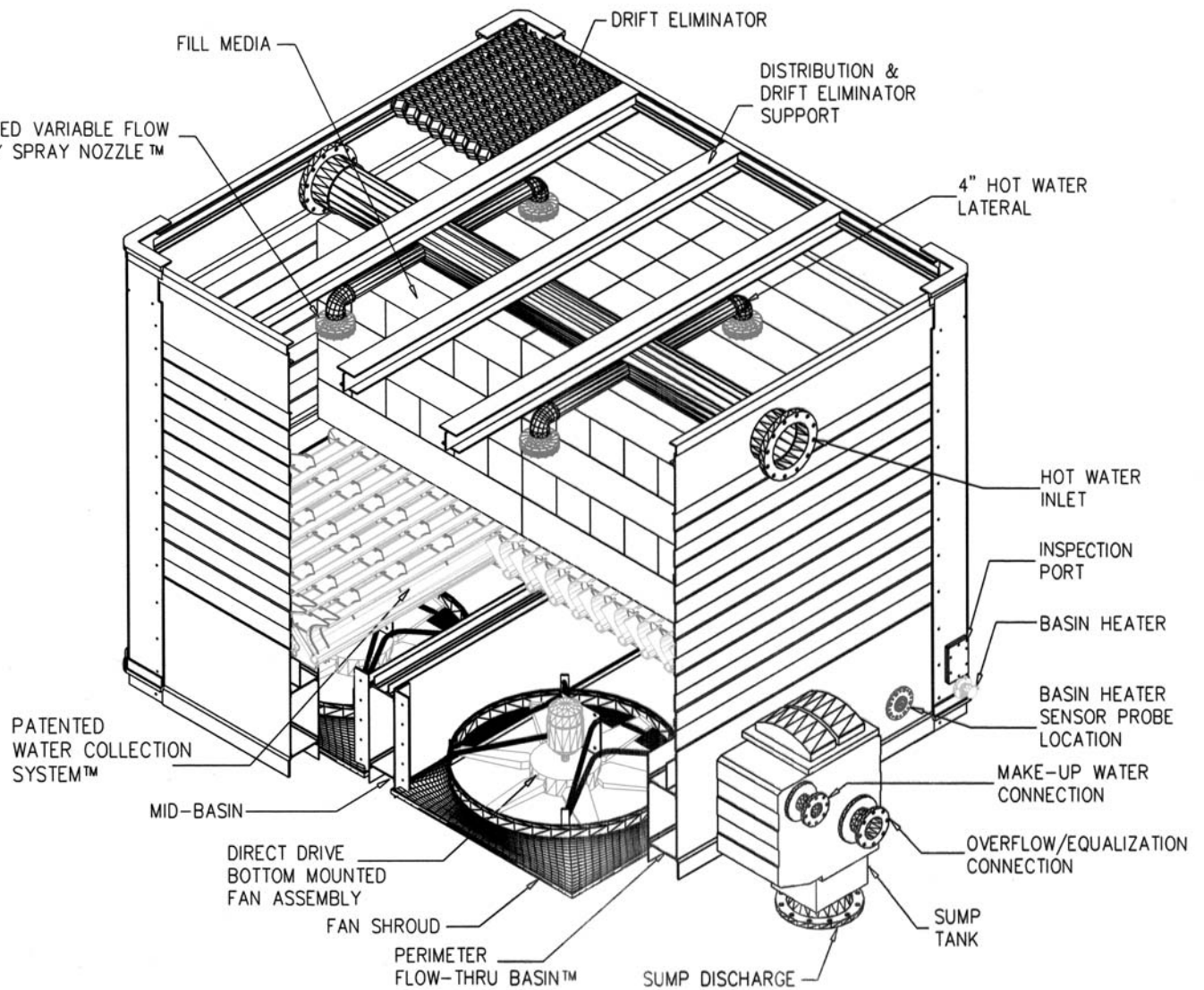

Unique design features include:

- Fully Enclosed Flow-Thru Basin™
- Variable-Flow Rotary Spray Nozzle™
- Water Collection System™
- Bottom Mounted Fans

Water Collection System™

TTXE's patented Water Collection System serves as an efficient collection chamber and conduit for channeling waterflow into the tower's Flow-Thru Basin™. Its unique shape aerodynamically moves inlet air into the fill media while effectively providing a leak free barrier protecting tower mechanicals.

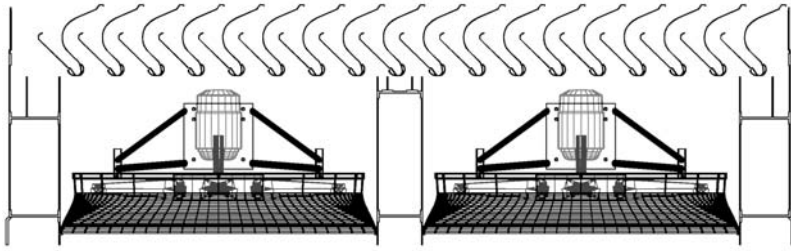

Flow-Thru Basin™

Unlike the low velocity cold-water settling basins common to conventional cooling tower designs, the TTXE tower incorporates a patented perimeter box beam which uniquely serves as both the cold water reservoir and provides the base structural component of the module. High water velocities in the basin beams continually scrub the walls and floor of the basin to eliminate the build-up of sediment and potentially bio-hazardous material – a common problem in conventional designs. Four access ports are provided for easy inspection.

Variable-Flow Rotary Spray Nozzle™

The patented Variable-Flow Rotary Spray Nozzle™ delivers even fill coverage across a broad range of system flows (~100-300 gpm/nozzle) at low pressures (0.5 – 1.5 psi). The nozzle requires less pressure to operate than a conventional nozzle, is virtually maintenance free, and dramatically improves lower performance.

Use of a lateral spray pattern allows the nozzle to be positioned just one inch off the fill material, saving several feet of pump head. The nozzle's turbine-driven rotor spins on a water bearing that keeps the nozzle parts from wearing, as well as provides the needed agitation to ensure virtually clog-free service. The rotary turbine produces a larger water droplet than conventional nozzles and thereby reduces drift loading on the drift eliminators for the lowest drift loss coefficient of any cooling tower.

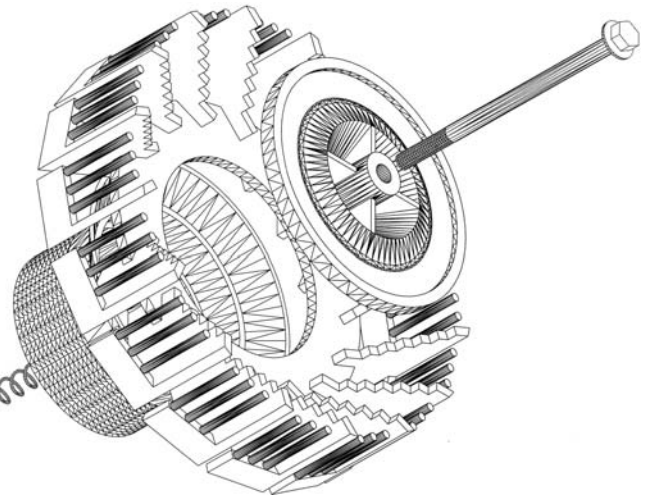

NOZZLE SPRAY DISTANCE
VERSUS FLOW

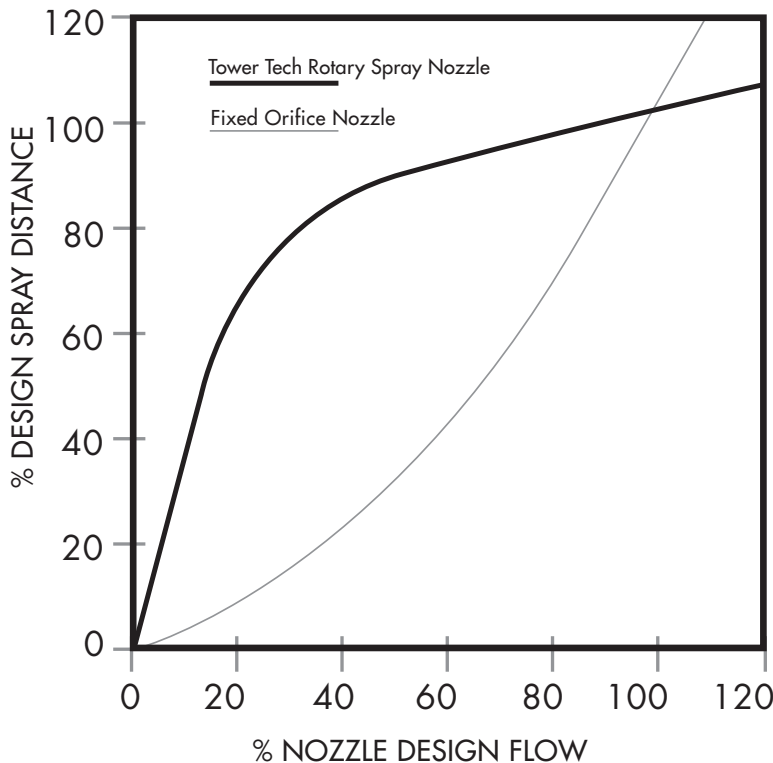

The chart demonstrates the constancy in spray pattern coverage at varying flow rates using the Rotary Spray Nozzle™. The nozzle orifice is shaped to provide an even square spray pattern, thereby uniformly wetting the entire tower's fill. This improves tower performance and reduces the likelihood of scaling due to the occurrence of dry regions within the fill. Variable-flow capability stems from the unique spring-actuated orifice which allows the nozzle to automatically adjust its pattern to changes in the flow rate, significantly reducing the down turn in performance observed with conventional nozzle designs. While conventional towers require a reduction in cell usage when system flow decreases, TTXE technology permits this reduced flow to be evenly distributed over all available fill area. This results in maximizing cooling capacity and energy efficiency under partial load duties.

Cooling Towers for Discerning Users™

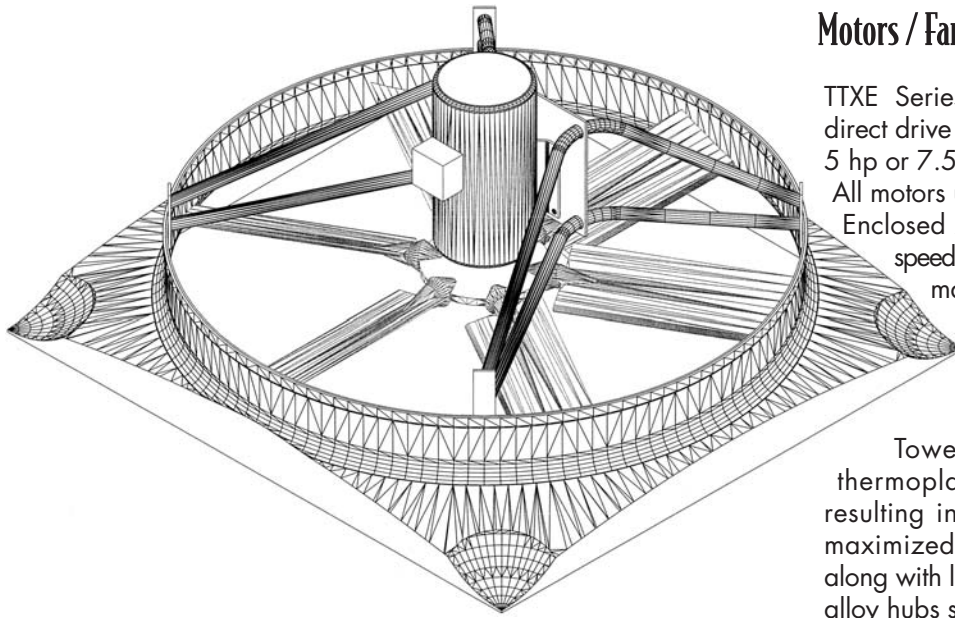

Motors / Fans/ Shrouds

TTXE Series standard model towers use high efficiency direct drive motors. Motor sizes available include 3, hp, 5 hp or 7.5 hp, depending on the tower model selected. All motors use a 215T frame size and are TEAO (Totally Enclosed Air Over). All motors operate at a nominal speed of 860 RPM. Motors from alternate manufacturers may be specified as special order items. Check with your Tower Tech Representative for more information.

Tower Tech fans use high-efficiency, molded thermoplastic blades with a unique airfoil design resulting in uniform airflow, minimal turbulence, and maximized system efficiency. Adjustable-pitch blades along with lightweight, high-strength cast aluminum-silicon alloy hubs simplify field adjustments. Blade tip tolerances are quality control validated in order to ensure maximum

system efficiencies. Tower Tech's stainless steel tubular motor mount provides minimum air turbulence, reduced fan noise, and long life for support of mechanical equipment.

The TTXE Series precision molded fan shroud is manufactured using hand-laid fiberglass techniques. It is engineered to provide a smooth air entry (optimized r/d) and approach velocity. The heavy-duty fiberglass shroud is lightweight and will resist corrosion indefinitely.

Fill & Drift Eliminators

TTXE Series cooling towers are equipped with five feet (5'-0") of rigid cross-corrugated, high-efficiency PVC film fill media (10 mil thickness). This fill media is resistant to biological degradation and to most chemicals (inorganic alkalis or acids, as well as organics) common to cooling tower systems. Its high surface area to volume ratio provides optimum heat exchange efficiency. The TTXE tower shell may be equipped with configurations to meet any water quality demand – alternative thermal capacity ratings are available from your Tower Tech design engineer. In addition to PVC, TTXE Series towers may be optionally equipped with HPVC fill suitable for use in "hot water" applications within a working range of 130 – 155°F. Alternative 15 mil thickness material is also available as a specified option.

TTXE Series cooling towers are equipped with low-pressure sinusoidal-wave shaped PVC drift eliminators (15 mil finished thickness). These high-efficiency cells (drift loss guaranteed not to exceed 0.0004%) force the exiting airstream to make three distinct directional changes causing exiting moisture droplets to impinge and coalesce on its high surface areas. The PVC material used in the construction is virtually impervious to rot, decay, or biological attack. An ultraviolet inhibitor manufactured into the product extends the life expectancy.

Materials of Construction

The Tower Tech TTXE Series cooling tower structure is factory-assembled and constructed entirely of fiberglass and stainless steel hardware, which together provide a rigid shell and framework for the tower that will resist deterioration and corrosion indefinitely. There are no galvanized or wood components which may leak potentially hazardous chemicals into the environment. Walls are joined together by tongue and groove joints and are sealed by a polyurethane sealant to prevent leaks. Stainless steel fasteners employing coated threads (in wetted areas) are used to bolt the walls together and ensure leak-free operation under pressurized operating conditions. Tower sub-structure is certified for seismic zones up to Zone 2. For greater seismic protection see your Sales Engineer for details.

Component	Material	Component	Material
Corner Enclosures	FRP (pultruded)	Sub-structure Legs	FRP (pultruded)
Shell/Casing	FRP (pultruded)	Windwall Partitions	PVC (extruded)
Fill Media	10 mil PVC	Modular Base Support	Nylon (injection molded)
Drift Eliminators	15 mil PVC	Fan Shroud	Hand-laid Fiberglass
Rotary Spray Nozzle™ (injection molded)	HDPE & Stainless Steel	Sump Box	PP (rotational mold)
Lateral Distribution	PVC	Inspection Ports	Nylon (injection molded)
Water Collection System™	ABS (injection molded & extruded)	Hardware	304 Stainless Steel
Header Inlet	PVC (injection molded)	Fan Support	304 Stainless Steel

Where FRP = Fiber-glass Reinforced, plastic Pultrusion; PVC = Poly Vinyl Chloride; HDPE = High Density Poly-Ethylene; ABS=Acrylonitrile, 1,3 Butadiene, and Styrene Copolymer, Flame Retardant; PP = Poly-Propylene.

Weights and Dimensions

TTXE Model	Weights (lb)		Dimensions (per illustration) ^a							
	Shipping	Operating	A	B	C	D	E	F	G	H
0219xx	5,000	8,500	7'-00"	4'-09"	9'-11"	1'-04"	4'-00"	6'-00"	17'-00"	13'-06"
0319xx	7,150	13,860	7'-00"	4'-09"	9'-11"	1'-04"	4'-00"	6'-00"	17'-00"	19'-03"
0419xx	8,380	15,180	12'-00"	6'-00"	9'-11"	1'-04"	6'-00"	6'-00"	17'-00"	13'-06"
0619xx	11,580	20,880	12'-00"	6'-00"	9'-11"	1'-04"	6'-00"	6'-00"	17'-00"	19'-03"
0819xx	13,950	25,090	12'-00"	6'-00"	9'-11"	1'-04"	6'-00"	6'-00"	17'-00"	25'-00"
1019xx	16,880	30,160	12'-00"	6'-00"	9'-11"	1'-04"	6'-00"	6'-00"	17'-00"	30'-09"

^a Dimensions are approximate and should not be used for construction purposes. Dimension F may be 4'-00" to 8'-00".

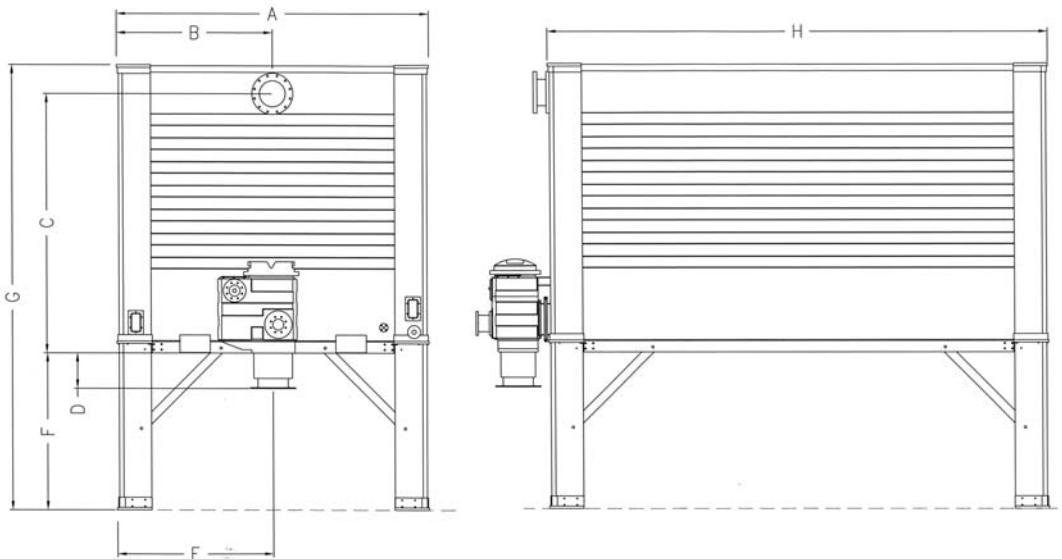

Engineering Data

TTXE Model	Fan Motor (3Ø, 60 HZ)							Connections			
	No. Fans	Volts	Amps/Fan	RPM	Efficiency ^o	HP/Fan	HP Total	Inlet Diam.	Outlet Diam.	Make-up Diam.	Overflow Diam.
021930	2	230 460	11.2 5.6	860	82.5	3	6	6	8	1 FNPT	4
021950	2	230 460	16.0 8.0	860	82.5	5	10	6	8	1 FNPT	4
021975	2	230 460	25.0 12.5	860	82.5	7.5	15	6	8	1 FNPT	4
031930	3	230 460	11.2 5.6	860	82.5	3	9	8	8	1 FNPT	4
031950	3	230 460	16.0 8.0	860	82.5	5	15	8	8	1 FNPT	4
031975	3	230 460	25.0 12.51	860	82.5	7.5	22.5	8	8	1 FNPT	4
041930	4	230 460	1.2 5.6	860	82.5	3	12	8	10	2 FNPT	6
041950	4	230 460	16.0 8.0	860	82.5	5	20	8	10	2 FNPT	6
041975	4	230 460	25.0 12.51	860	82.5	7.5	30	8	10	2 FNPT	6
061930	6	230 460	1.2 5.6	860	82.5	3	18	10	12	2 FNPT	6
061950	6	230 460	16.0 8.0	860	82.5	5	30	10	12	2 FNPT	6
061975	6	230 460	25.0 12.51	860	82.5	7.5	45	10	12	2 FNPT	6
081930	8	230 460	1.2 5.6	860	82.5	3	24	12	14	2 FNPT	6
081950	8	230 460	16.0 8.0	860	82.5	5	40	12	14	2 FNPT	6
081975	8	230 460	25.0 12.51	860	82.5	7.5	60	12	14	2 FNPT	6
101930	10	230 460	1.2 5.6	860	82.5	3	30	12	14	2 FNPT	6
101950	10	230 460	16.0 8.0	860	82.5	5	50	12	14	2 FNPT	6
101975	10	230 460	25.0 12.5	860	82.5	7.5	75	12	14	2 FNPT	6

a Standard motors are high efficiency, TEAO severe duty, standard direct drive with L-10 sealed bearings, 1.15 service factor, inverter duty with quantum shield wiring, class "F" insulation (minimum).



Thermal Performance Data *Thermal capacities assume 6' air inlet.*

Model	Fan Power		GPM Cooling Capacity at Indicated Operating Conditions								
	No. Fans	HP Total	HWT °F	95	100	93	98	97	102	95	100
			CWT °F	85	85	83	83	87	87	85	85
			WBT °F	78	78	78	78	80	80	80	80
21930	2	6		465	385	377	316	487	403	394	331
021950	2	10		543	449	439	368	568	470	460	386
021975	2	15		594	489	479	399	621	511	501	418
031930	3	9		683	566	553	465	714	592	579	486
031950	3	15		797	659	645	542	834	690	675	567
031975	3	22.5		872	718	703	587	912	751	736	615
041930	4	12		869	721	705	593	908	755	737	621
041950	4	20		1012	839	820	690	1058	877	858	722
041975	4	30		1106	912	893	748	1157	954	934	782
061930	6	18		1271	1055	1031	868	1328	1103	1079	909
061950	6	30		1484	1231	1203	1013	1552	1287	1259	1060
061975	6	45		1626	1341	1313	1099	1700	1402	1374	1150
081930	8	24		1672	1389	1357	1143	1747	1451	1420	1196
081950	8	40		1954	1620	1583	1333	2042	1694	1656	1396
081975	8	60		2135	1762	1725	1444	2232	1842	1805	1511
101930	10	30		2073	1722	1683	1418	2166	1800	1759	1484
101950	10	50		2423	2009	1964	1655	2532	2101	2054	1732
101975	10	75		2648	2184	2139	1791	2768	2285	2238	1875

Model	Fan Power		GPM Cooling Capacity at Indicated Operating Conditions								
	No. Fans	HP Total	HWT °F	91	96	89	94	90	95	80	85
			CWT °F	81	81	79	79	80	80	70	70
			WBT °F	74	74	74	74	70	70	60	60
021930	2	6		426	352	344	288	502	408	404	327
021950	2	10		497	411	402	336	587	476	472	382
021975	2	15		544	446	437	365	644	520	518	417
031930	3	9		625	517	505	424	737	599	593	480
031950	3	15		729	603	590	494	861	699	693	561
031975	3	22.5		798	655	642	536	945	763	760	612
041930	4	12		795	659	644	542	937	763	755	612
041950	4	20		926	767	750	630	1092	888	880	713
041975	4	30		1013	833	816	683	1198	969	965	777
061930	6	18		1162	764	942	793	1370	1115	1103	895
061950	6	30		1359	1125	1100	925	1602	1302	1290	1047
061975	6	45		1488	1226	1200	1005	1761	1424	1418	1143
081930	8	24		1530	1269	1240	1044	1802	1467	1452	1178
081950	8	40		1788	1480	1447	1218	2108	1714	1698	1378
081975	8	60		1954	1610	1576	1320	2312	1870	1862	1501
101930	10	30		1897	1574	1538	1295	2234	1818	1800	1461
101950	10	50		2217	1836	1795	1511	2614	2125	2106	1708
101975	10	75		2423	1997	1955	1638	2867	2318	2309	1862

Cooling Towers for Discerning Users™

Sub-Structure/Multiple Modules % Capability Correction

Inlet Ht (ft)	% Capability Correction (3 HP Models)					Number of Modules				
	1	2	3	4	5	6	7	8	9	10
021930										
4	0.999	0.997	0.995	0.994	0.993	0.992	0.992	0.991	0.991	0.990
6	1.000	0.999	0.998	0.998	0.997	0.997	0.997	0.996	0.996	0.996
8	1.000	1.000	0.999	0.999	0.999	0.999	0.998	0.998	0.998	0.998
031930										
4	0.999	0.995	0.993	0.990	0.988	0.986	0.985	0.984	0.983	0.982
6	1.000	0.999	0.997	0.996	0.995	0.994	0.994	0.993	0.993	0.993
8	1.000	1.000	0.999	0.998	0.998	0.997	0.997	0.997	0.996	0.996
041930										
4	0.998	0.995	0.993	0.992	0.991	0.990	0.990	0.989	0.989	0.989
6	1.000	0.999	0.998	0.998	0.997	0.997	0.997	0.996	0.996	0.996
8	1.001	1.000	1.000	1.000	0.999	0.999	0.999	0.999	0.999	0.999
061930										
4	0.997	0.992	0.988	0.985	0.983	0.982	0.980	0.979	0.978	0.978
6	1.000	0.998	0.996	0.994	0.994	0.993	0.992	0.992	0.991	0.991
8	1.001	1.000	0.999	0.998	0.997	0.997	0.997	0.996	0.996	0.996
081930										
4	0.997	0.989	0.983	0.978	0.974	0.972	0.970	0.968	0.966	0.965
6	1.000	0.996	0.994	0.991	0.990	0.989	0.987	0.987	0.986	0.985
8	1.001	0.999	0.998	0.996	0.995	0.994	0.994	0.993	0.993	0.993
101930										
4	0.996	0.986	0.978	0.971	0.966	0.962	0.958	0.956	0.953	0.951
6	1.000	0.995	0.991	0.989	0.986	0.984	0.982	0.981	0.980	0.979
8	1.001	0.999	0.996	0.995	0.993	0.992	0.991	0.990	0.990	0.989

Inlet Ht (ft)	% Capability Correction (5 HP Models)					Number of Modules				
	1	2	3	4	5	6	7	8	9	10
021950										
4	0.999	0.997	0.995	0.994	0.993	0.992	0.992	0.991	0.991	0.991
6	1.000	0.999	0.998	0.998	0.997	0.997	0.997	0.997	0.996	0.996
8	1.000	1.000	0.999	0.999	0.999	0.999	0.999	0.998	0.998	0.998
031950										
4	0.999	0.996	0.993	0.990	0.988	0.987	0.985	0.984	0.984	0.983
6	1.000	0.999	0.997	0.996	0.995	0.995	0.994	0.993	0.993	0.993
8	1.000	1.000	0.999	0.998	0.998	0.997	0.997	0.997	0.996	0.996
041950										
4	0.998	0.995	0.993	0.992	0.991	0.990	0.990	0.989	0.989	0.989
6	1.000	0.999	0.998	0.997	0.997	0.996	0.996	0.996	0.996	0.996
8	1.001	1.000	0.999	0.999	0.999	0.999	0.999	0.998	0.998	0.998
061950										
4	0.997	0.992	0.988	0.986	0.983	0.982	0.981	0.980	0.979	0.978
6	1.000	0.998	0.996	0.995	0.994	0.993	0.993	0.992	0.991	0.991
8	1.001	1.000	0.999	0.998	0.998	0.997	0.997	0.997	0.996	0.996
081950										
4	0.997	0.989	0.983	0.978	0.975	0.972	0.970	0.968	0.967	0.965
6	1.000	0.997	0.994	0.992	0.990	0.989	0.988	0.987	0.986	0.985
8	1.001	0.999	0.998	0.997	0.996	0.995	0.994	0.994	0.993	0.993
101950										
4	0.996	0.986	0.978	0.972	0.966	0.962	0.959	0.956	0.954	0.952
6	1.000	0.996	0.992	0.989	0.986	0.984	0.982	0.981	0.980	0.979
8	1.001	0.999	0.997	0.995	0.993	0.992	0.991	0.990	0.989	0.989

Inlet Ht (ft)	% Capability Correction (7.5 HP Models)					Number of Modules				
	1	2	3	4	5	6	7	8	9	10
021975										
4	0.999	0.997	0.995	0.994	0.993	0.993	0.992	0.991	0.991	0.991
6	1.000	0.999	0.998	0.998	0.997	0.997	0.997	0.997	0.996	0.996
8	1.000	1.000	0.999	0.999	0.999	0.999	0.999	0.998	0.998	0.998
031975										
4	0.999	0.996	0.993	0.990	0.988	0.987	0.986	0.984	0.984	0.983
6	1.000	0.999	0.997	0.996	0.995	0.995	0.994	0.993	0.993	0.993
8	1.000	1.000	0.999	0.998	0.998	0.997	0.997	0.997	0.996	0.996
041975										
4	0.998	0.995	0.993	0.991	0.991	0.990	0.989	0.989	0.989	0.988
6	1.000	0.999	0.998	0.997	0.997	0.996	0.996	0.996	0.996	0.995
8	1.001	1.000	0.999	0.999	0.999	0.999	0.999	0.998	0.998	0.998
061975										
4	0.997	0.991	0.988	0.985	0.983	0.981	0.980	0.979	0.978	0.978
6	1.000	0.997	0.996	0.994	0.993	0.993	0.992	0.992	0.991	0.991
8	1.001	0.999	0.998	0.998	0.997	0.997	0.996	0.996	0.996	0.995
081975										
4	0.997	0.989	0.983	0.978	0.975	0.972	0.971	0.968	0.967	0.966
6	1.000	0.996	0.994	0.992	0.990	0.989	0.988	0.987	0.986	0.985
8	1.001	0.999	0.998	0.997	0.996	0.995	0.994	0.994	0.993	0.993
101975										
4	0.996	0.987	0.979	0.972	0.967	0.963	0.960	0.957	0.954	0.952
6	1.000	0.996	0.992	0.989	0.986	0.984	0.983	0.981	0.981	0.980
8	1.001	0.999	0.997	0.995	0.994	0.992	0.992	0.991	0.990	0.989

The thermal performance of the TTXE Series cooling towers is certified by the Cooling Technology Institute in accordance with its standard STD-201(02) and has been assigned CTI validation number 04-17-04. This certification is your assurance that the proposed capacities accurately reflect actual cooling tower performance. CTI certification under STD-201(02) is limited to thermal operating conditions with entering wet bulbs between 60°F and 85°F, a maximum process fluid temperature of 125°F, a cooling range of 4°F or greater, and a cooling approach of 5°F or greater.



OPTIONAL EQUIPMENT

Motor Pre-Wire

TTXE Series Modular Cooling Towers™ are shipped with motors factory pre-wired to a central junction box (NEMA-4X). Motors can be factory pre-wired to individual "lock-out/tag-out" rotary disconnect switches. Motor wiring used is Alpha brand shielded 12-4 AWG oil resistant, VFD compatible, liquid tight flexible cable.

Sub-Structure Kits

Each Modular Cooling Tower has a 1-foot high stub leg kit for mounting on customer furnished support structure. As an option, towers can be furnished with leg kits from 4 feet to 8 feet in height. The most common configuration uses 6-foot high legs to allow convenient access to the fan inlet of the tower for inspections and maintenance. Sub-structure kits include FRP legs with integrated footpads (Nylon), angle braces (FRP), and stainless steel assembly hardware; and are shipped loose for installation at the time of delivery and tower installation.

Control Panels

Panels are high quality, UL rated, NEMA 4 enclosures (epoxy painted steel) equipped for single-point wiring to a manual disconnect. Each control panel includes power distribution to individual motor starters with lockout disconnect, magnetic overload protection, and solid-state adjustable thermal overload protection. There is a door mounted H-O-A switch and RUN pilot light for each motor starter. Auxiliary motor starter contacts can be provided. A solid-state PLC is provided for supply water temperature control with a door-mounted operator interface display panel and a Type K thermocouple or RTD temperature sensor for remote mounting in the customer's tower discharge piping.

Standard water temperature control is done with fan staging through the pre-programmed PLC.

Variable Frequency Drives

Optional water temperature control can be done with a remote mounted variable frequency drive (VFD) suitable for multiple motor operation. The VFD output is wired to the control panel disconnect switch. The output frequency of the VFD can be controlled through the pre-programmed PLC by means of a 4-20 ma or 0-24V analog output. If the VFD is bypassed for any reason, the PLC returns to fan staging control.

Operating Tower Tech cooling tower fans through a VFD provides the tightest temperature control possible at the very lowest energy consumption. When operated with variable water flow, the combination of the VFD and the variable flow Rotary Spray Nozzle™ provide energy saving opportunities that no other cooling tower can match. Call your Tower Tech sales representative for details.

Basin Heaters

Stainless steel electric immersion heaters are recommended when operating in low ambient temperature conditions in order to protect against basin freezing when the tower is shut down. A NEMA 4X control panel is provided to control up to 4 individual elements (6 kW each). A remote temperature sensor is provided for mounting in the tower basin and the controller is preset to 45 degrees F. All heating elements must be located within the same tower water basin as the sensing element. Threaded flanges are installed in the tower's cold water basin for mounting each heating element and the temperature sensor. The control panel must be field mounted and wired to each heating element and the temperature sensor. A power source separate from the cooling tower fans is recommended.

Variable Flow Offers Lowest \$ kW/Ton

Conventional water distribution in cooling towers sacrifices valuable energy saving opportunities. This fact is even more pronounced in today's water filming style heat transfer medias.

The efficiency of evaporative heat transfer is affected by the air-to-water contact area and the mass flow liquid-to-gas ratio. In general, for a given heat load and water mass flow rate, the more surface area involved, the less required air velocity over the water surface, and consequently the less air-moving fan horsepower. If you want lower kW/ton, buy more air-to-water contact surface area.

Film media, such as the popular PVC cross-fluted corrugated film block, provides a breakthrough in cooling tower design. It greatly increases the contact surface area without increasing the size of the tower box. Adversely, it suffers quickly from scaling and biomass fouling in very compact air channels that negatively impact the flow of air.

Precise water treatment is required to prevent bio growth fouling and the fill must remain "wetted" to avoid evaporative scaling. Conventional water distribution uses fixed orifice spray nozzles that produce a round pattern above a rectangular fill pack. The nozzles are placed in a rectangular overlapping pattern to assure full wetting of the fill at the design water flow rate.

Water flow rates below the design point will not produce a full spray pattern and void areas will start to appear. Any fill's best efficiency is achieved when the liquid-to-gas ratio is evenly balanced throughout the fill media. Short patterns and overlapping patterns cannot accomplish it.

When a cooling tower system is faced with a variable water flow rate (i.e. multiple pump cycling or variable speed pumping) these pattern problems force the operator to isolate

whole cooling tower cells to maintain proper water distribution under reduced load in the remaining on-line cells. If this is not done, the tower efficiency will suffer and the fill media will quickly foul. Isolating cells takes away air-to-water contact surface.

A water distribution system that can respond to variable flow rates and keep all of the fill media evenly wetted and in service is needed. This requires a nozzle that responds to flow changes to keep a constant pattern. A square pattern that avoids overlap would be best.

Putting this system on a three-cell tower with three matched pumps would yield the following opportunities. A typical tower would operate at 0.06 kW/ton for the tower alone at full load, 0.06 kW/ton at 2/3 load (two cells operating at 100%), and 0.06 kW/ton at 1/3 load (one cell operating at 100%). Under the same conditions, a constant pattern, variable spray system with variable speed drives on the fan motors would operate at 0.06 kW/ton at full load, 0.024 kW/ton at 2/3 load (all cells operating at 2/3 load), and 0.005 kW/ton at 1/3 load (all cells operating at 1/3 load).

These energy savings can only be achieved through use of a constant pattern, variable flow distribution system. This patented system is available for evaporative water-cooling towers at one place, only: Tower Tech. Come visit us at www.TowerTechInc.com to see our complete line of factory-assembled, modular fiberglass cooling towers for flow rates from 200 gpm to 200,000 gpm and more. Our towers are CTI Certified under STD-201 for your assurance of performance. We're worth a second look for a great many reasons. Check us out.

*Barry A. Woods, P.E.
Tower Tech, Inc.*

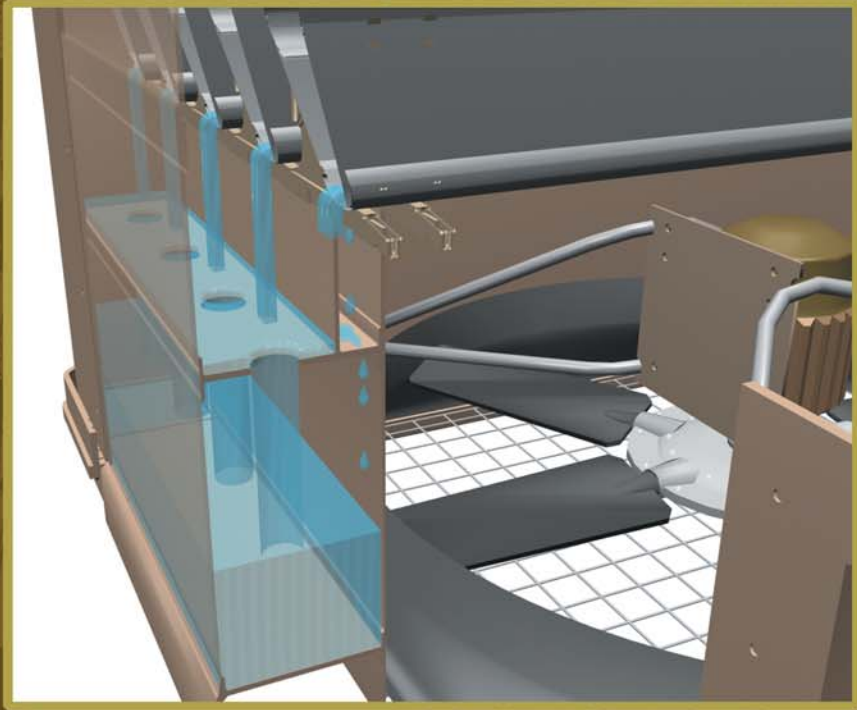

P.O. Box 891810, Oklahoma City, OK 73189-1810, Tel: 405-290-7788, Fax: 405-979-2131
Visit us at www.TowerTechInc.com